



**The World's Leading
Manufacturer Of Trailer Sliders
For Over Three Decades.**

9200



Slider Series

Parts & Installation



Advancing the Practical Application of Suspension Technology

Springfield, MO ■ (800) 654-8824 ■ (417) 862-5012
Fax (417) 862-2317 ■ www.hutchensindustries.com

9200 Slider Series

Application

The 9200 slider is specially designed for van trailers traveling in Northern, foul weather climates. Hard winters and corrosives can take their toll on standard sliders, but the 9200 holds its own against the damaging effects of sub-freezing climates. Designed in a "C" channel construction, the 9200 fights rust and corrosion by eliminating those areas where moisture and salts can collect.

Advantages

- ▶ Longer Subframe Life...Reducing The Need For Replacement
- ▶ Easier Maintenance With Less Downtime
- ▶ Available With A "Hot Dipped" Galvanized Coating For Even Greater Corrosion Protection
- ▶ Comes With The Most Comprehensive Extended Warranty Available

Capacity

The 9200's gross axle weight rating (G.A.W.R.) is limited to a maximum of 25,000 lbs./axle.

Features

- ▶ A spring loaded, locking-pin mechanism utilizing forged lock pins.

- ▶ Open end, "C" channel frame rails prevent the build-up of dirt, salts and water...minimizing the opportunity for corrosion.
- ▶ 4 symmetrical crossmembers for uniform stress distribution.
- ▶ Heavy gauge, roll formed, low-profile body rails with holes punched in 4 inch increments allowing precise variations in vehicle weight distribution while providing the wheel base best suited to your needs.
- ▶ Hutch's locator bar...the best compromise in weight and strength. Solid steel plugs welded at each end of a steel tube bar make repositioning fast and easy.
- ▶ Bolt-on hangers for maximum serviceability.

Options

The 9200 slider is available in frame widths/spring centers of 38" and 44". Contact the factory for widespread sliders. The standard 9200 model slider has an overall height of 10 1/2", as measured from the top of the body rail to the bottom of the sliding subframe. However, a 9 1/2" model is available. Special length body rails and hole locations are available upon request.

How to order your 9200 Slider Assembly

1. Determine the frame width (FW)/spring centers (SC) you require. **See Fig. 1.**
2. Select the range of slide adjustment you need and what body rail length will provide that range. **See Chart B.**
3. A locator bar assembly is a standard component with every Hutchens slider. **See Chart C.** The locator bar should be used as directed when positioning the slider. **See "To Position The Sliding Suspension."**
4. Each slider must be ordered by a description of the slider.

Example:

A 9200 slider with 44" spring centers, 9700T flange mount bolt-on hangers and pipe braces attached, 192" body rails, and a locator bar assembly would be ordered as follows:

Quantity	Model	FW/SC	Body Rail Length
1 ea.	9200	44"	192"

w/ Locator Bar

*w/ 9700T flange mount bolt-on hangers attached**

* If you are ordering a complete suspension with the slider, a description of the unit must follow (i.e. 3/4" seats for 5" round axles, less standard 3 leaf springs with 7040-08 U-bolts).

Fig. 1

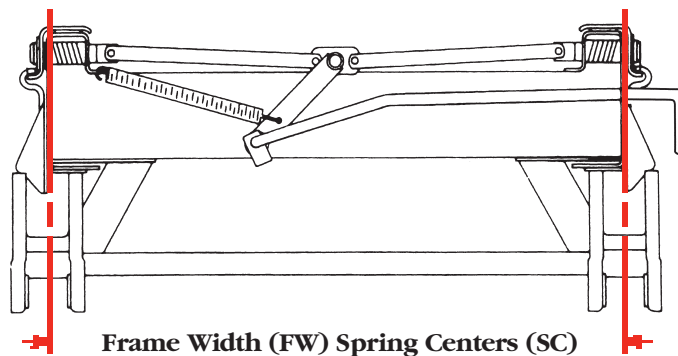



9200

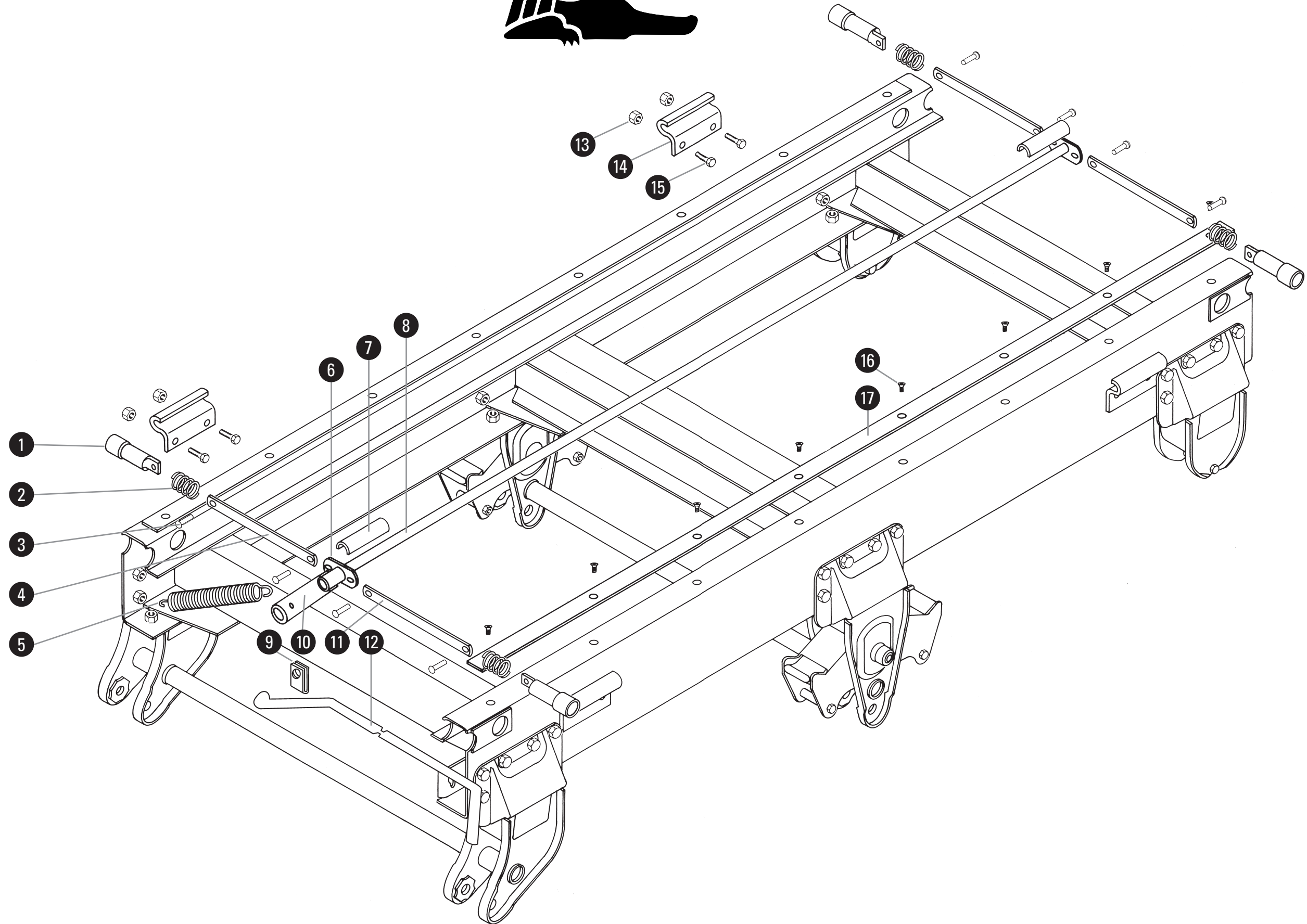

Bill of Materials

Item	Part No.	Quantity	Description
1	12716-01	4	Forged Lock Pin
2	12779-01	4	Compression Spring - Lock Pin, PL
3	12780-01	8	Pan Head Rivet
4	See Chart A	2	Link (varies with frame width)
5	8018-02	2	Spring - Helex, 12 GA x 1 PD x 10 1/8"
6	8028-00	2	Cam - Puller Kit
7	12785-01	2	Pipe Channel, U-Shaped
8	8010-14	1	Pipe - 1" STD x 95"
9	11409-01	1	Handle Clip
10	8026-00	1	Crank - Puller Kit
11	11412-13	2	Link - 16.62" OAL
12	18010-02	1	Pull Handle - 30" LG
13	33-01	8	Hex Lock Nut - 1/2" - 20 UNF
14	12715-01	4	Hold Down Clip
15	8040-00	8	Hex Bolt - 1/2" - 20 UNF x 1 1/4" LG, GR5
16	9627-00	16	Thread Form Screw 5/16" - 18" x 3/4", CSHD
17	11421-01	2	Slider Pad - UHMW, 1/4" x 2" x 96"

Chart A - Link (Item #4)

Part No.	Frame Width/Spring Centers	Overall Length (OAL)
11412-01	38"	10.62"
11412-13	44"	16.62"

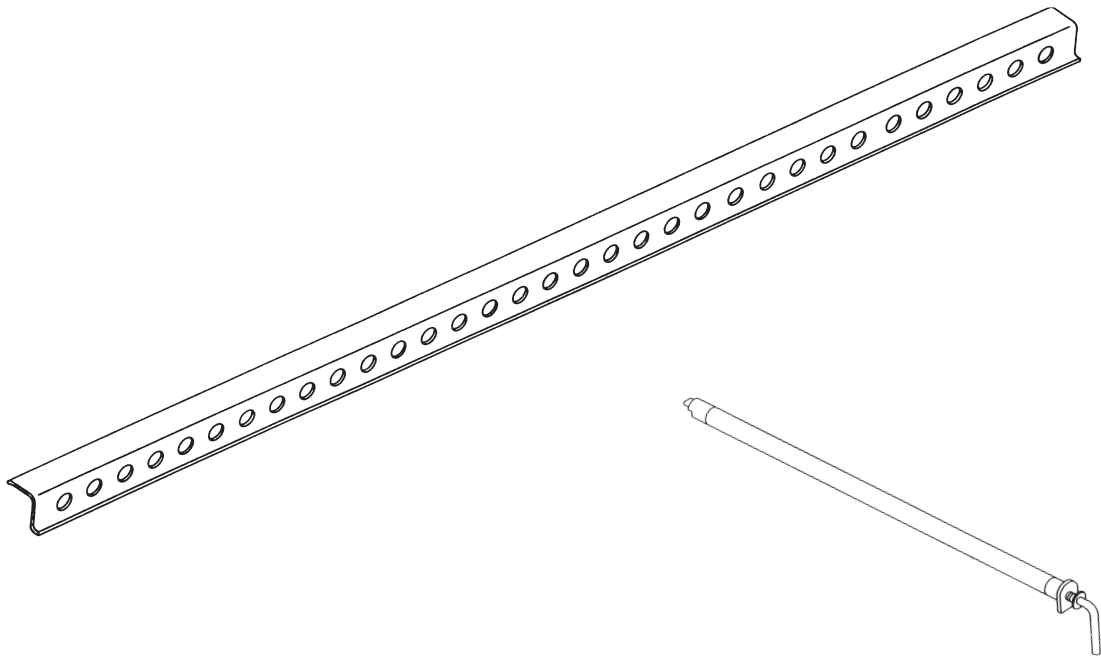

Chart B - Body Rail Assemblies

Part No.	Length Ranges	Material Thickness
12713-XX	80" - 328"	.232"
16816-XX	92" - 328"	.275"

Chart C - Locator Bar Assemblies

Part No.	Frame Width
11642-11	38"
11642-12	44"

Hangers:

All "Hutch" sliders leave the factory with hangers and pipe braces attached. However, should the spring hangers need to be replaced, the following points should be noted.

Fig. 2

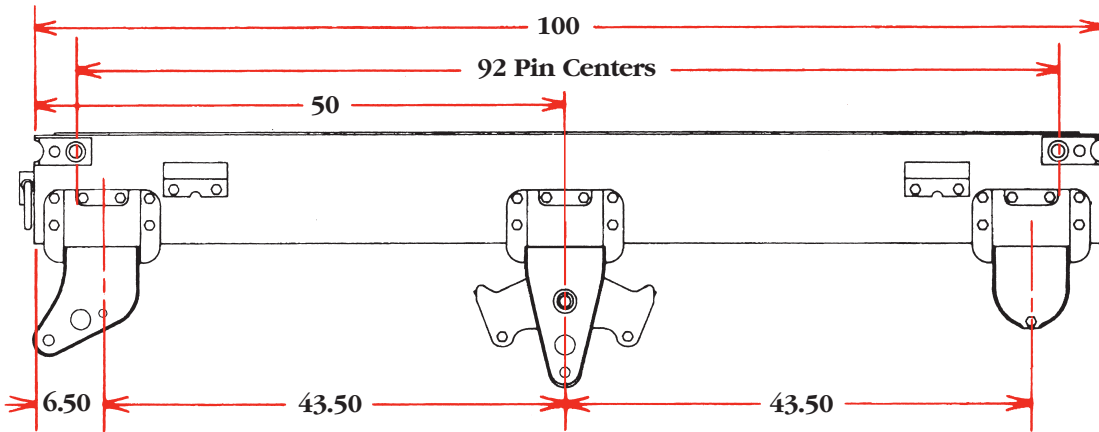

1. The flange mount bolt-on hangers are to be installed using the pre-punched holes in the slider side rail. A 5/8", grade 5 (or better) bolt is required. A total of forty-eight 1 1/2" bolts (Part No. 11512-07) and locknuts (Part No. 11513-03) are required for sliders with standard 49" axle centers. The 1 1/2" bolts attach the hangers to the slider side rail. These bolts are secured to the side rail by a 5/8" locknut. These bolts should be torqued to the bolt manufacturer's specifications. See Fig. 3.

Fig. 3

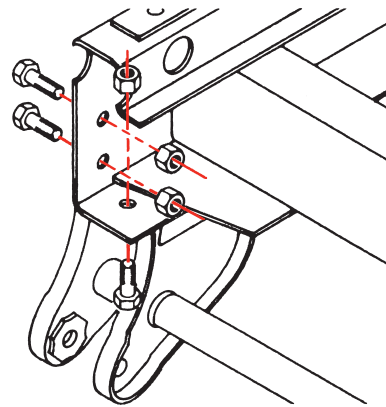

Body Rails:

2. Determine the location of the body rails. This is done by measuring out from the centerline of the trailer one-half of the frame width and adding 5/16 of an inch. This locates the **inside** of the body rail. This measurement should be performed at the front and rear of each body rail. See Fig. 4a.

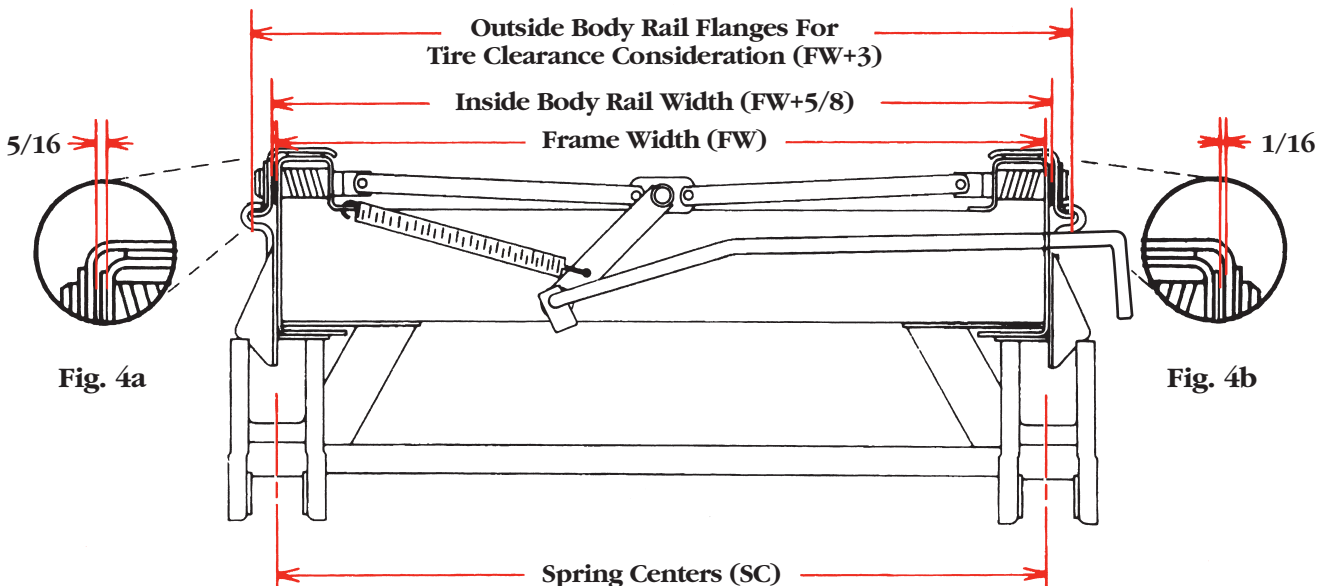

3. Clamp the body rails in position under the trailer.

- a) When locating body rails on the trailer cross sills, it is helpful if the slider lock pins are centered in the body rail holes on both sides.
- b) Use one 1/16" shim **on each side** or one 1/8" shim **on one side** to get the proper lateral spacing between body rails and the bearing plate on the slider frame. **See Fig. 4b.** Check spacing to make sure the 1/8" space (overall) is constant along the full length of the rails.

4. Weld the body rails securely to the underside of the trailer.

5. Remove shims and check unit for free operation along the entire length of the body rails.

Note: Each trailer manufacturer may have their own preferred method of effecting body rail alignment and attachment.

6. On all sliders the trailer structure must block the front and rear rail openings to prevent the slider frame from escape. **See Fig. 5.**

Fig. 5

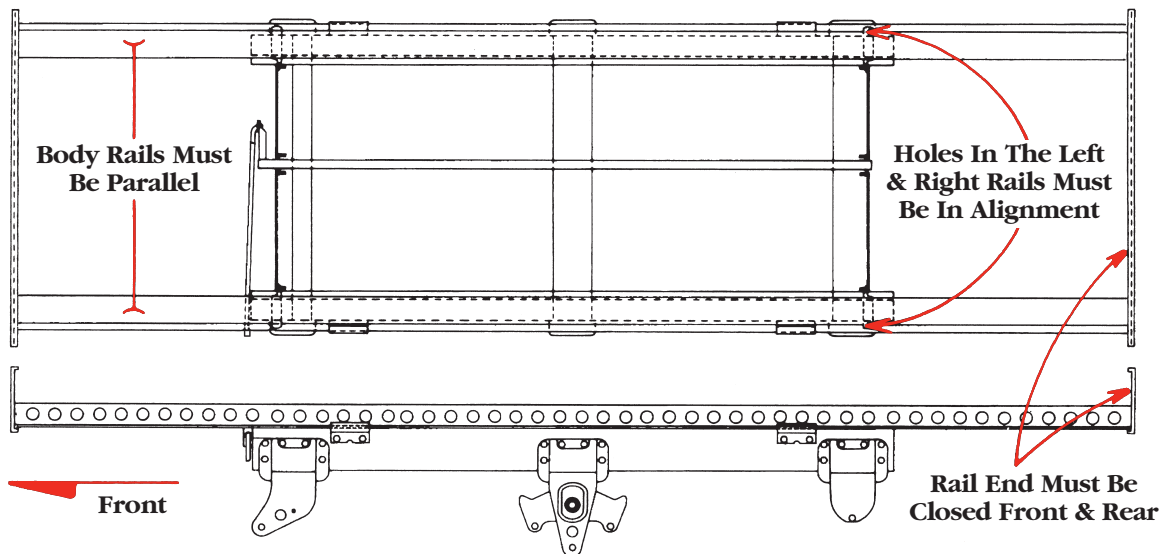

Hold Down Clips:

- 7.** Secure the hold down clips at each corner of the slider assembly. Each clip requires two 1/2" diameter bolts and lock nuts, which are furnished by Hutchens. Tighten the nuts and bolts to 65 lb-ft (oiled), 85 lb-ft (dry) torque.

Suspension Alignment:

ALIGNMENT CAN ONLY BE ACHIEVED IF THE LOCKPIN HOLES ARE EVENLY LOCATED FROM THE KINGPIN, LEFT AND RIGHT. ALIGNMENT SHOULD ALWAYS BE DONE WHILE THE TRAILER IS EMPTY.

To properly align the suspension attached to your 9200 slider, the trailer should be pulled in a straight line for a sufficient distance to ensure there are no binds in the suspension. The trailer should then be pulled straight forward with the trailer brakes locked, so the locking pins rest against the rear of the holes in the body rails. This approximates the position of the pins when the trailer is being pulled on a highway, and ensures proper trailer tracking. Alignment can be achieved with an optical device especially for this purpose, or manually in the following manner.

- a) Measure the distance from the kingpin to the centerline of the spindles on the front axles. It is recommended that spindle extensions be utilized. As noted in **Fig. 6**, dimensions A and B must be equal within 1/8 of an inch. Alignment is accomplished by loosening the torque arm clamp bolts on both ends of the adjustable torque arm and turning the adjustment screw as required.

Fig. 6

$$A = B \pm 1/8$$
$$C = D \pm 1/16$$
$$E \leq 1/4$$

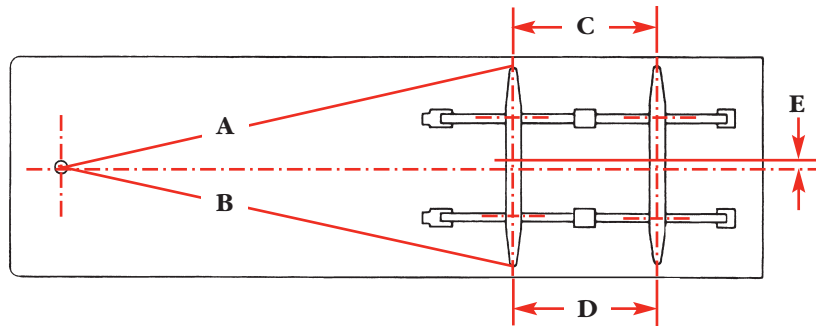

b) After the front axle is aligned, tighten the 5/8" torque arm clamp bolts to 130 lb-ft (oiled), 170 lb-ft (dry) torque in order to lock the position of this axle. Next, align any succeeding axles with the front axle following the same procedure.

- ▶ Loosen the torque arm clamp bolts, turn the adjustment screw until dimensions C and D are equal within 1/16" of each other, then tighten the clamp bolts to the proper torque.
- ▶ Check dimension E, the lateral centerline relationship of the trailer body and axles. If E exceeds 1/4", contact the trailer manufacturer for recommendations.
- ▶ After alignment has been completed on all axles, all 5/8" torque arm clamp bolts should be rechecked to make certain that they are tightened to the necessary 130 lb-ft (oiled), 170 lb-ft (dry) torque.
- ▶ Relocate the slider to the forward position and recheck the kingpin alignment. Variance in A and B dimensions would indicate lock pin hole discrepancies.
- ▶ Refer to TTMA RP No. 71-05 (Trailer Axle Alignment) for more detail.

To Position The Sliding Suspension:

1. Set both the tractor and trailer brakes.
2. Remove the locator bar from behind the slider and move to desired location.
3. To release the lock pins, pull the operating handle all the way out and lock in place.
4. Release the tractor brakes and carefully drive forward or backward until the sliding suspension is at the desired location.
5. Release the operating handle and visually check all lock pins for locking. The main body of each lock pin must extend through the holes in the rails.
6. Lock the locator bar in both rails immediately behind the slider.
7. With the trailer brakes applied, gently rock the trailer backward and forward to ensure the sliding suspension is properly locked, and follow the procedures set out above before pulling the trailer. The lock pins must be checked at each stop to ensure each is locked.

Important: Warning Decal Note

When the installation of your "Hutch" slider is complete and the trailer and/or subframe has been painted, the decal (shown here) must be installed in plain view on the road side of the trailer immediately above the suspension. The decal must be in plain view on each trailer equipped with a "Hutch" slider, and must be read before using the sliding suspension. Decals are shipped with the slider units. If decals are not received, or if for any reason additional decals are wanted, contact our Customer Service Department at (417) 862-5012 or fax (417) 862-2317 and decals will be shipped promptly at no charge.

